

ÖGE NO.	PARÇA NUMARASI	TANIM	MİKT.
1	TEL KAFES-03	ø3,5 L=	12
2	HALKA-03		11
3	ALT KAPAK-03		1
4	VENTURY-03		1

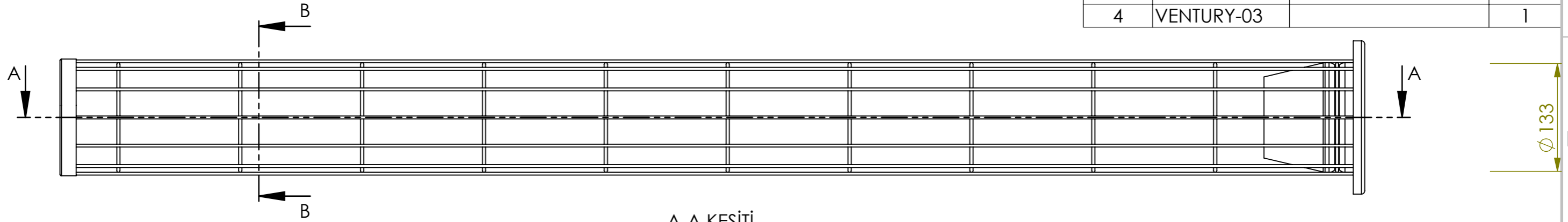

A-A KESİTİ
(1 : 5)

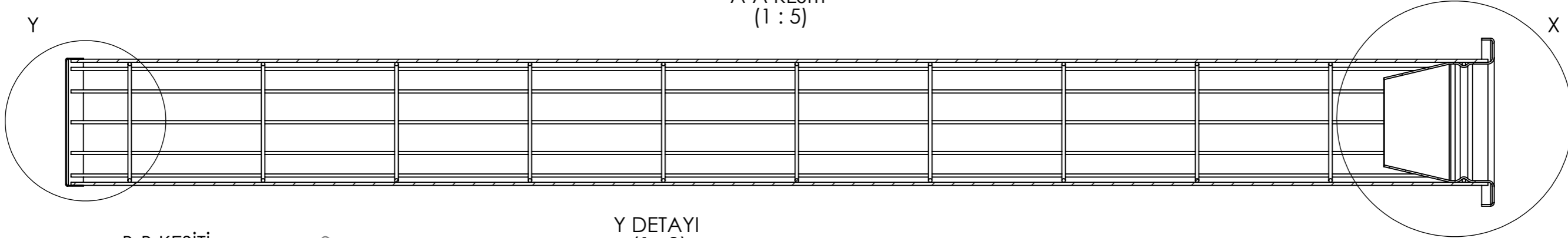

Y DETAYI
(1 : 3)

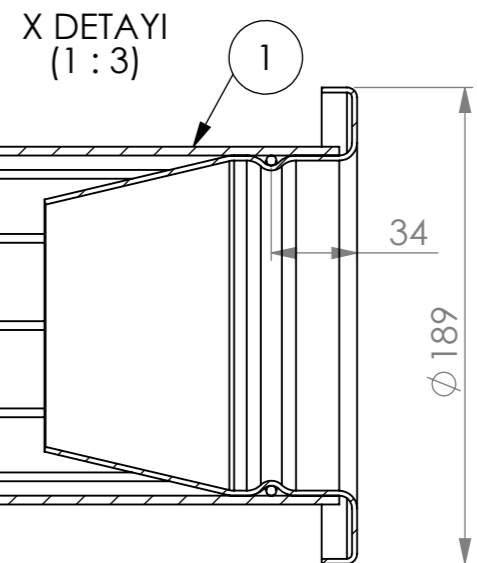

X DETAYI
(1 : 3)

B-B KESİTİ
(1 : 3)

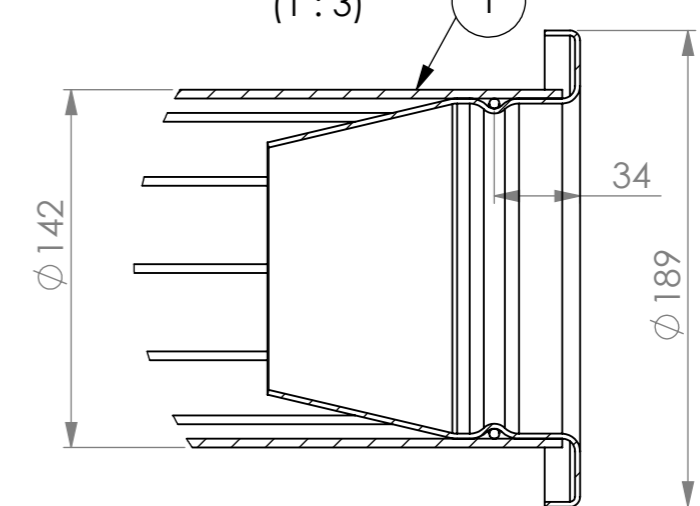
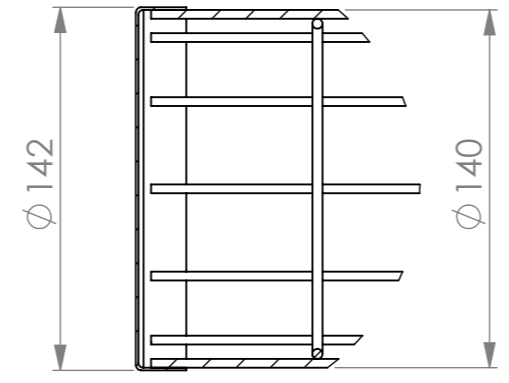
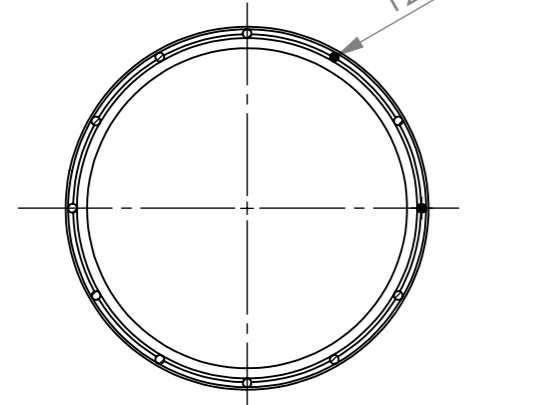

POZ-3
(1 : 3)

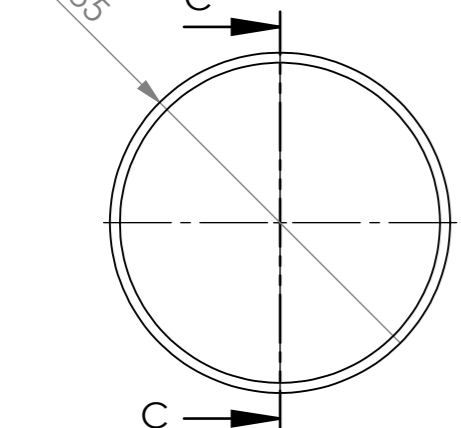

C-C KESİTİ
(1 : 3)

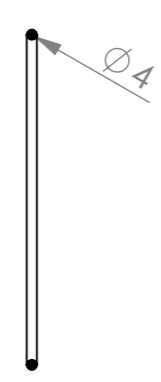

POZ-3
(1/4)

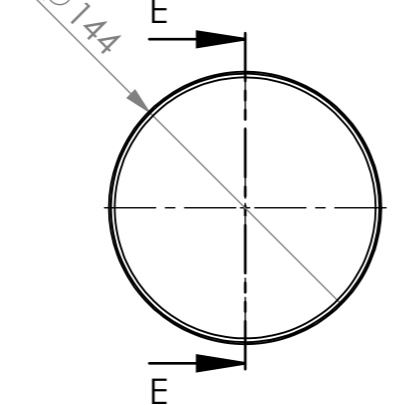

E-E KESİTİ
(1 : 4)

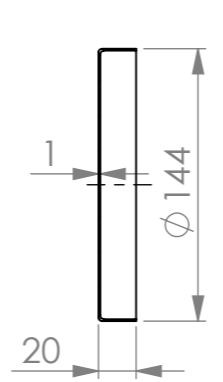

AKSI BELİRTİLMEDİĞİ SÜRECE: BOYUTLAR MİLMETREDİR YÜZEY CİLASI: TOLERANSLAR: DOĞRUSAL: AÇISAL:		BİTİRME:		KESKİN KENARLARI PAHLAYIN VE KIRIN		TEKNİK RESMİ ÖLÇEKLENDİRMEYİN		REVİZYON	
ÇİZEN	Orhan DURSUN	İMZA	TARİH			BAŞLIK:			
DENET.						MERTSAL MAKİNA MÜHENDİSLİK			
ONAY.						RESİM NO.			
ÜRET.						140x03 MONTAJ		A3	
KALİTE				MALZEME:		ÖLÇEK: 1:10		SAYFA 1 / 1	
				AĞIRLIK:					