

POP PERÇİN İLE MONTAJLANACAKTIR.
(ÇEVREDE 4 ADET 4x6)

X DETAYI
(1 : 4)

Y DETAYI
(1 : 4)

ÖĞE NO.	PARÇA NUMARASI	TANIM	MİKT.
1	VENTURY		1
2	ÜST KAPAK		1
3	HALKA		48
4	ALT KAPAK		1
5	KAFES TEL		16
6	BAĞLANTI HALKASI		1
7	BİRLEŞTİRME PARÇASI		1
8	KAFES TEL		16
9	KİLİT		1

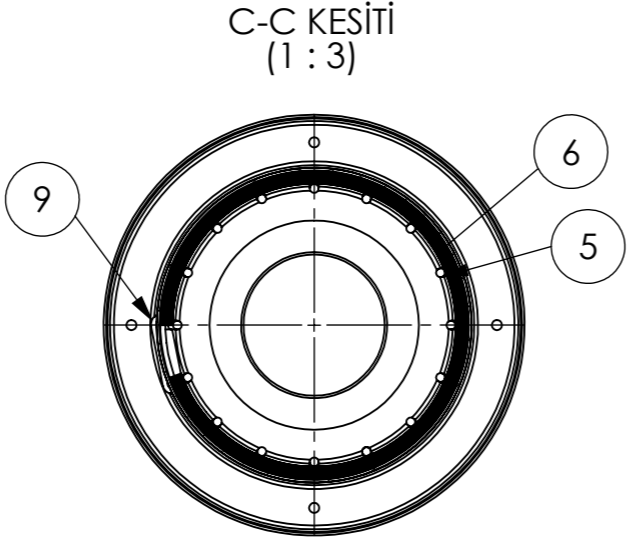
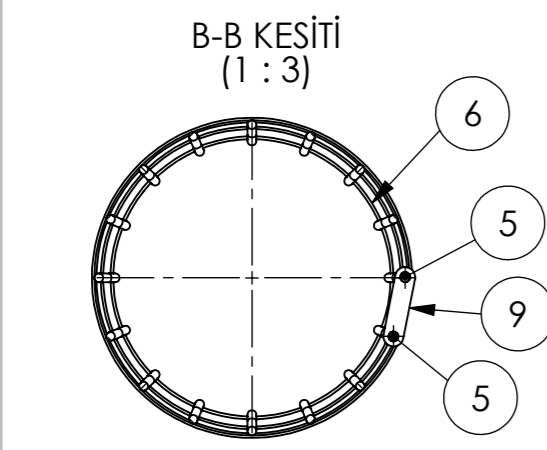
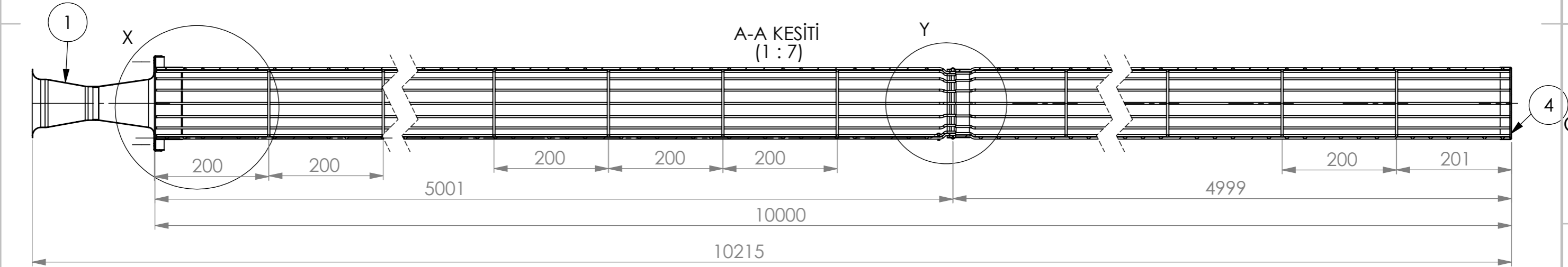
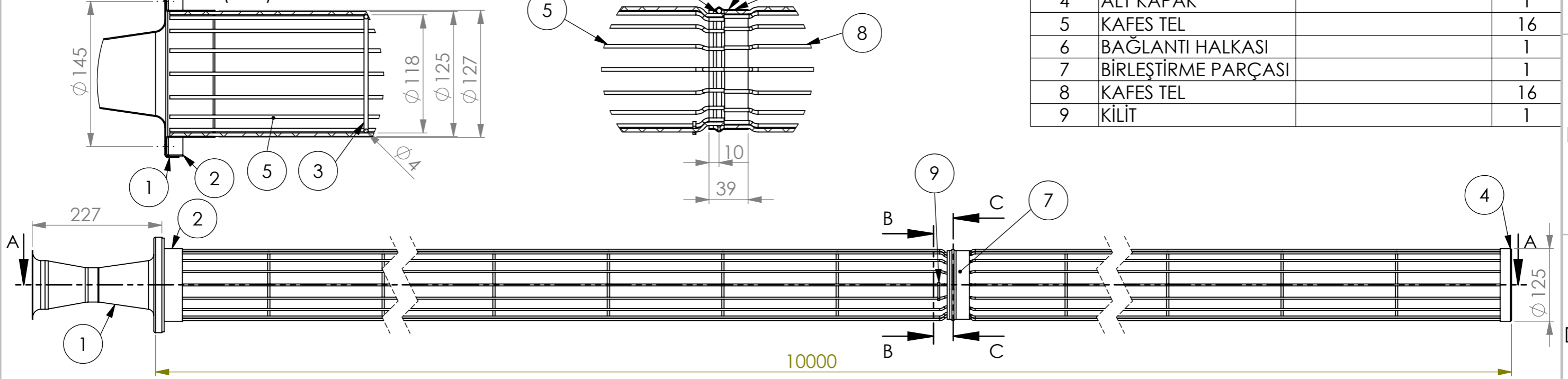

AKSI BELİRTİLMEDİĞİ SÜRECE: BOYUTLAR MİLİMETREDİR YÜZEY CİLASI: TOLERANSLAR: DOĞRUSAL: AÇISAL:	BİTİRME:	KESKİN KENARLARI PAHLAYIN VE KIRIN	TEKNİK RESMİ ÖLÇEKLENDİRMEYİN	REVİZYON
ÇİZEN ORHAN DURSUN	İMZA	TARİH	BAŞLIK: MERTSAL MAKİNA MÜHENDİSLİK	
DENET.			RESİM NO. 127x10000 MONTAJ 2-1	
ONAY.			A3	
ÜRET.			ÖLÇEK: 1:10	
KALİTE		MALZEME:	SAYFA 1 / 1	
		AĞIRLIK:		